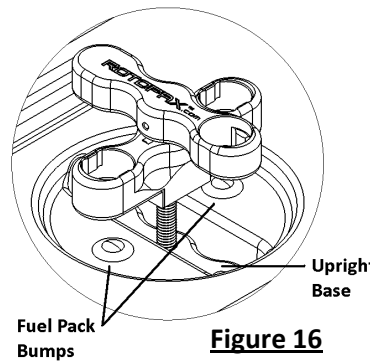
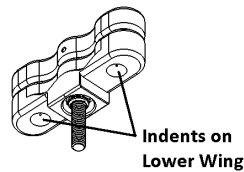


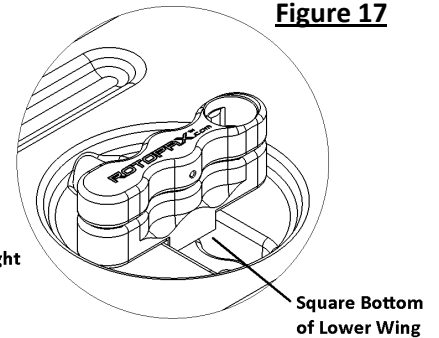
## LOX T-Handle

**Step 1** – Insert the LOX T-Handle into the Upright Base then tighten to desired tension while keeping the indents on the underside of the Lower Wing aligned with the Fuel Pack bumps (see **Figures 15** and **16**).

**Figure 15**

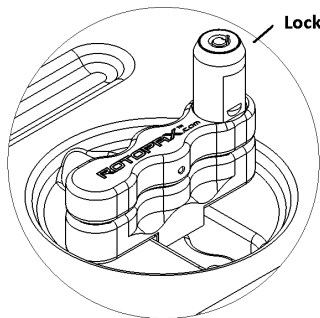


**Figure 17**

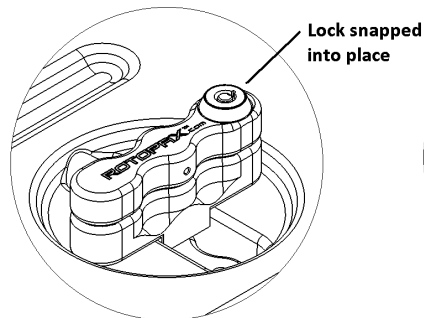


**Step 2** - Ensure that the square bottom of the Lower Wing has been snugly inserted into the hole of the Fuel Pack and that the Lower Wing and the Upper Handle are aligned (see **Figure 17**).

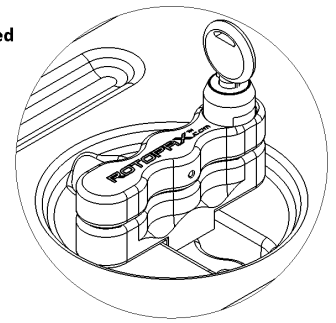
**Step 3** - Insert lock into the hole and push down until you hear the lock snap into place. The handle is now locked (see **Figure 18** and **19**).



**Figure 18**



**Figure 19**



**Figure 20**

**Step 4** - To remove lock, insert key into lock, twist key and pull out (see **Figure 20**).

**Note:** To ensure extended life, lubricate the lock periodically.